

02D	D103 > MA4P1250. ECO 50-0411	TS	X	X	X	29-10-99
08	X	X	X	X	X	X
02A	RXMOD	CJK				28/04/99
01B	UPDATED SYNTH PA RX,1ST PROTO	BRD				
REV/ISS	AMENDMENTS	DRAWN	CHKD	D.O.	APVD	DATE

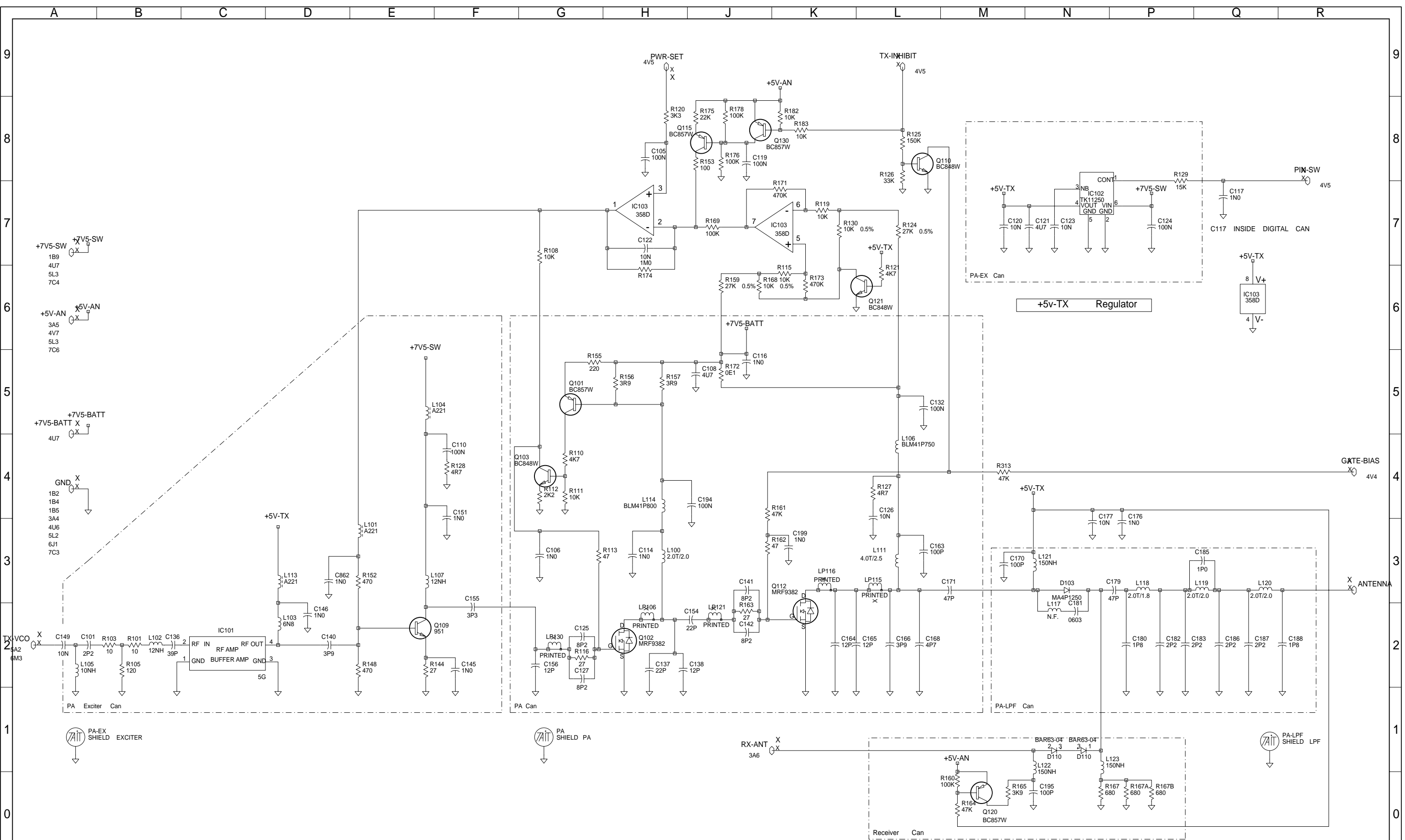

© TAIT ELECTRONICS
 ORCA :TOP- SYSTEM DIAGRAM 800MHZ
 IPN: 220-01416-02 ISSUE: C ID: 2.S.C. 1
 PROJECT: ORCA DESIGNER: CJK/TS FILE NAME: 141602d FILE DATE: 2-Aug-99 NO.SHEETS: 7



L121 L122 L123 150n 1008

© TAIT ELECTRONICS	
ORCA :TOP-POWER AMPLIFIER	800MHZ
IPN: 220-01416-02	ISSUE: C 2.S.C. 2
PROJECT: ORCA	DESIGNER: CJK/TS
FILE NAME: 141602d	FILE DATE: 2-Aug-99
NO.SHEETS: 7	

REV/ISS	AMENDMENTS	DRAWN	CHKD	D.O.	APVD	DATE
A						

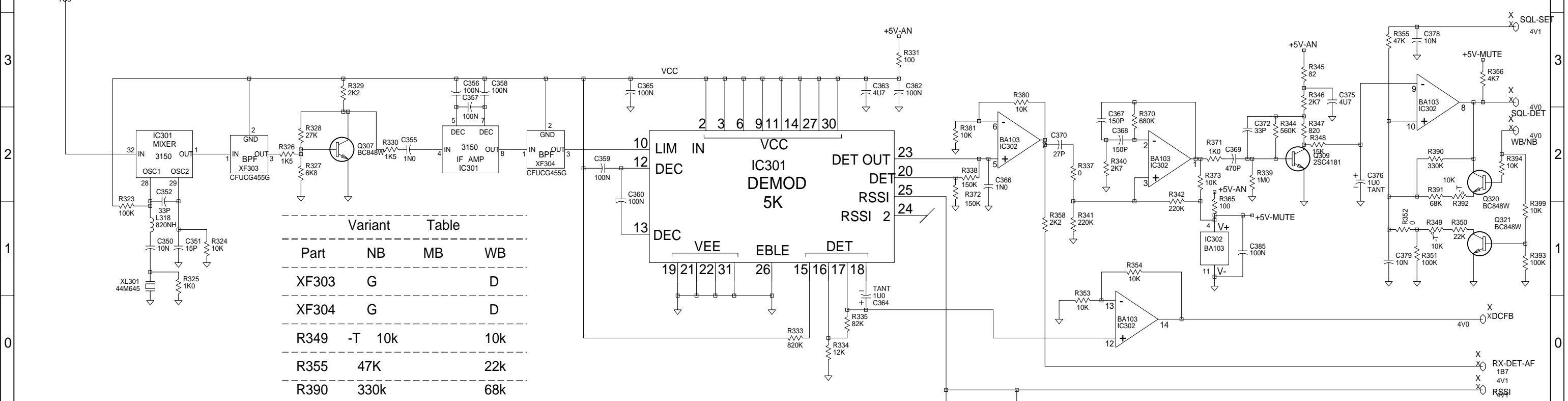
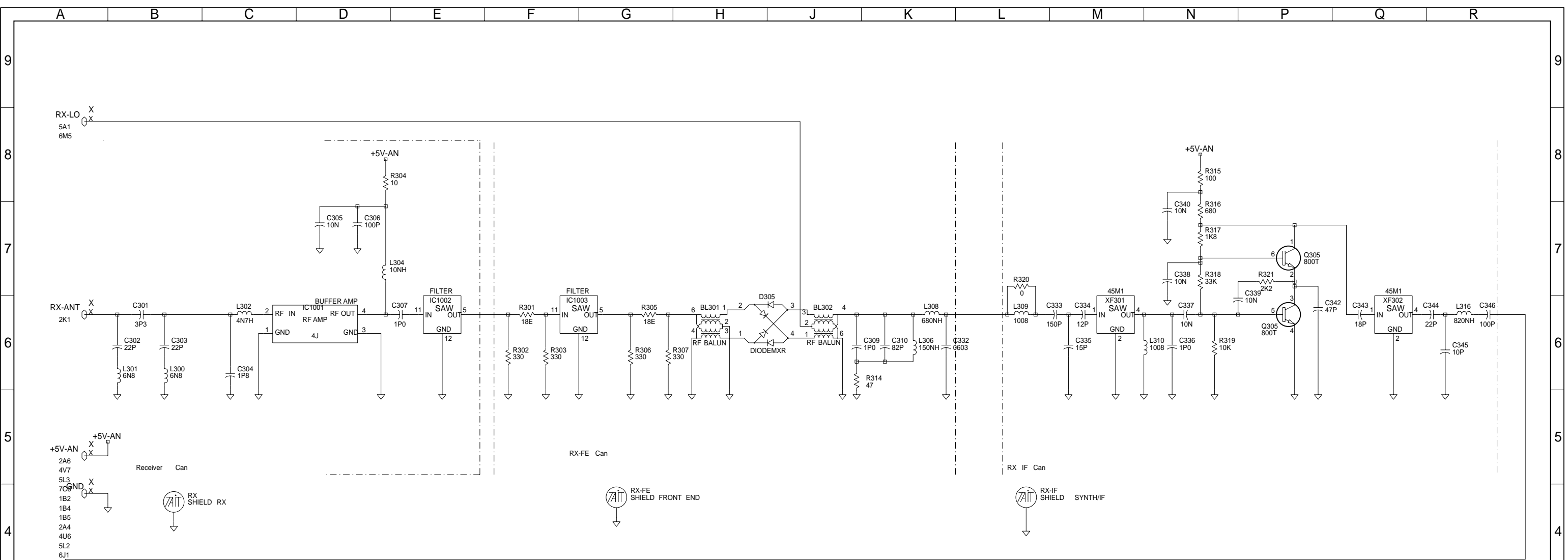

Variant Table

Part	NB	MB	WB
XF303	G		D
XF304	G		D
R349	-T	10k	10k
R355	47K		22k
R390	330k		68k
C370	27p		22P
C369	470p		330P

© TAIT ELECTRONICS
 ORCA :TOP- RECEIVER 800MHZ
 IPN: 220-01416-02 ISSUE: C ID: 2.S.C. 3
 PROJECT: ORCA DESIGNER: CJK/TS FILE NAME: 141602d FILE DATE: 2-Aug-99 NO.SHEETS: 7

REV/ISS	AMENDMENTS	DRAWN	CHKD	D.O.	APVD	DATE
A						

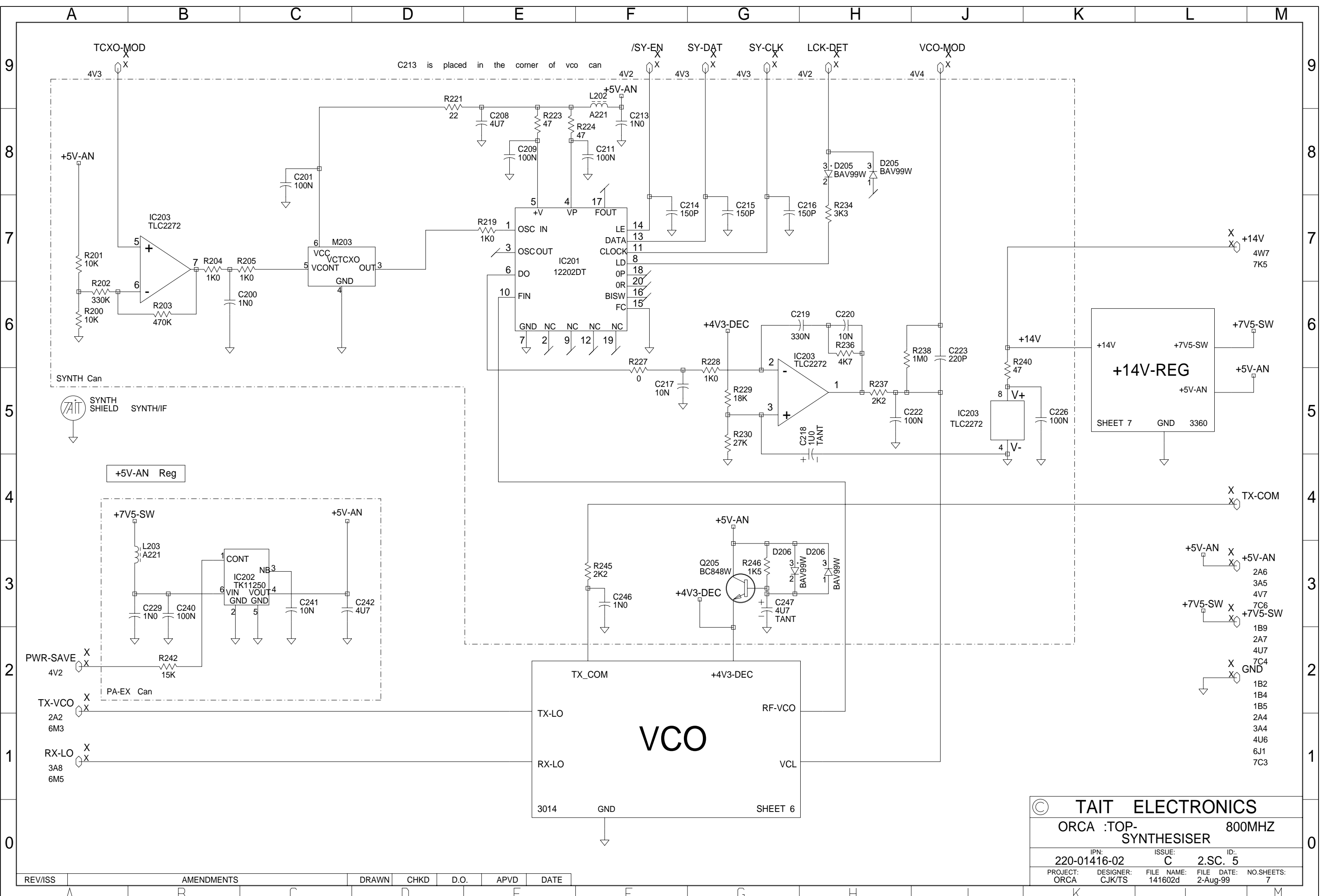

© TAIT ELECTRONICS

ORCA :TOP- 800MHZ
SYNTHESISER

IPN: 220-01416-02 ISSUE: C ID: 2.SC. 5

PROJECT: ORCA DESIGNER: CJK/TS FILE NAME: 141602d FILE DATE: 2-Aug-99 NO.SHEETS: 7

REV/ISS	AMENDMENTS	DRAWN	CHKD	D.O.	APVD	DATE

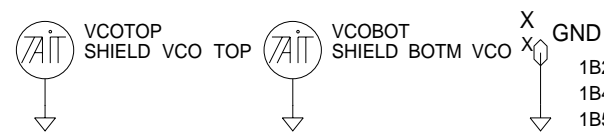
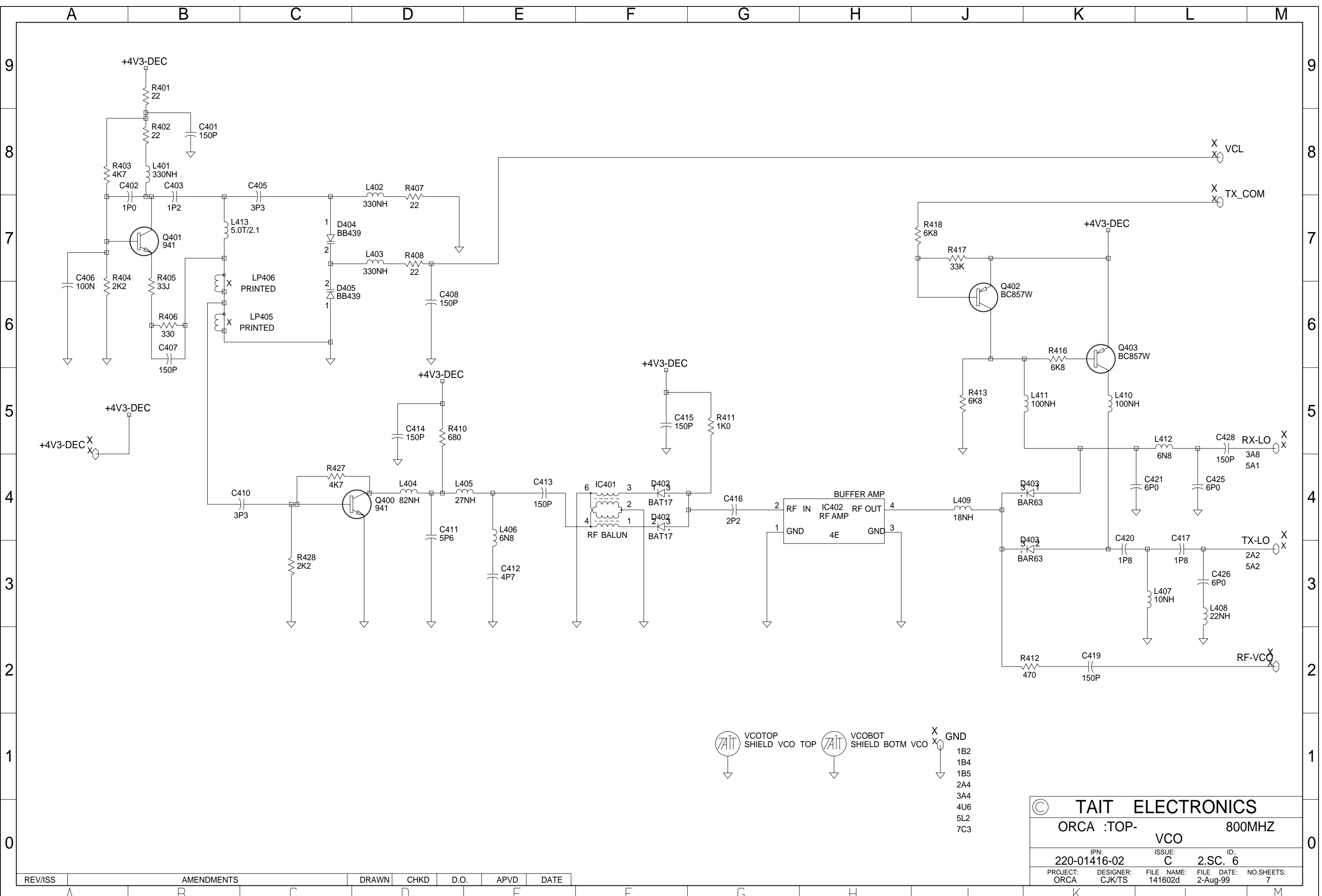

© TAIT ELECTRONICS			
ORCA :TOP-		800MHZ	
VCO			
IPN:	ISSUE:	ID:	
220-01416-02	C	2.SC.	6
PROJECT:	DESIGNER:	FILE NAME:	FILE DATE:
ORCA	CJK/TS	141602d	2-Aug-99
			NO.SHEETS:
			7

REV/ISS	AMENDMENTS	DRAWN	CHKD	D.O.	APVD	DATE

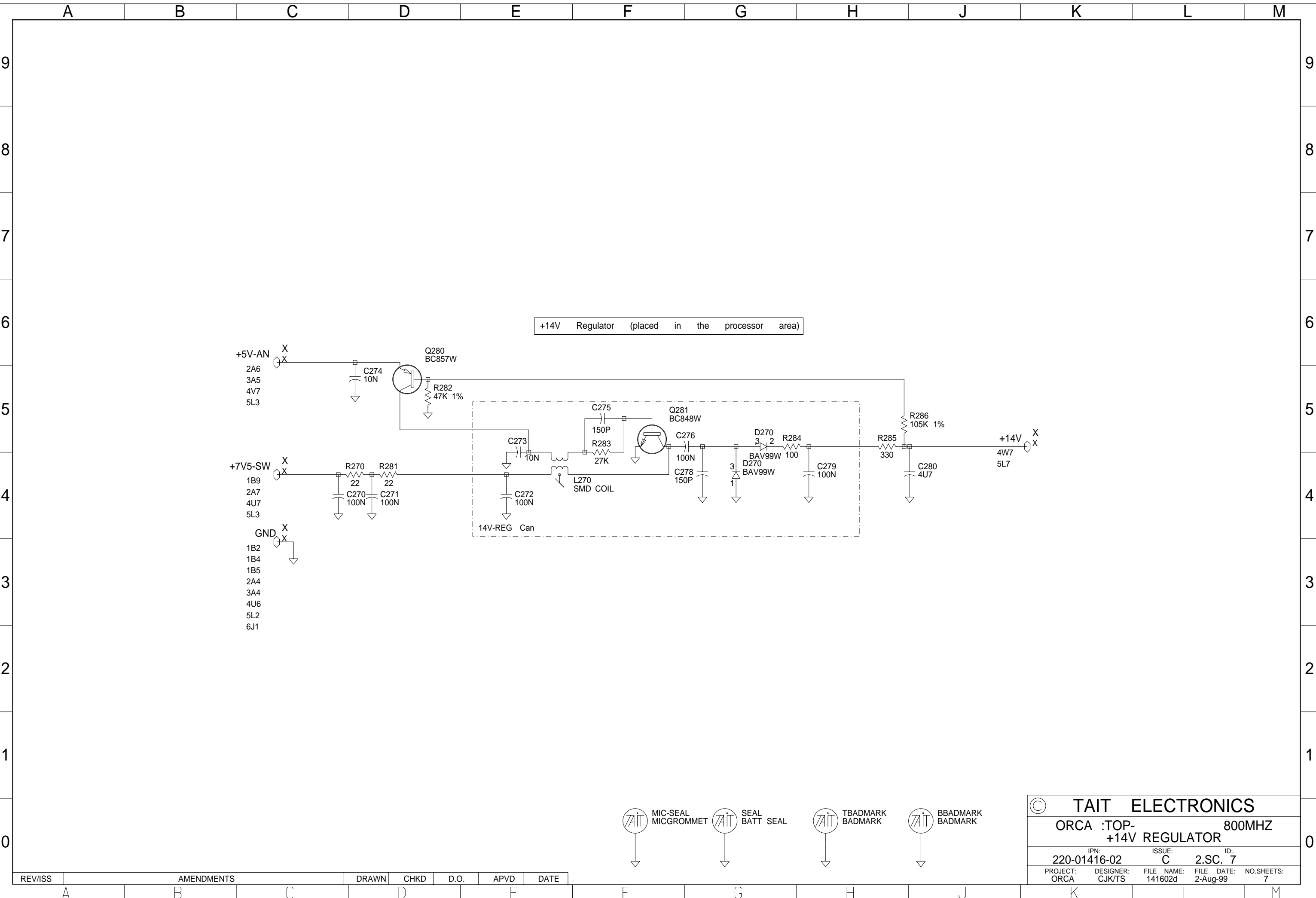

- MIC-SEAL MICGROMMET
- SEAL BATT SEAL
- TBADMARK BADMARK
- BBADMARK BADMARK

© TAIT ELECTRONICS				
ORCA :TOP-		800MHZ		
+14V REGULATOR				
IPN: 220-01416-02		ISSUE: C	ID: 2.SC. 7	
PROJECT: ORCA	DESIGNER: CJK/TS	FILE NAME: 141602d	FILE DATE: 2-Aug-99	NO.SHEETS: 7

REV/ISS	AMENDMENTS	DRAWN	CHKD	D.O.	APVD	DATE

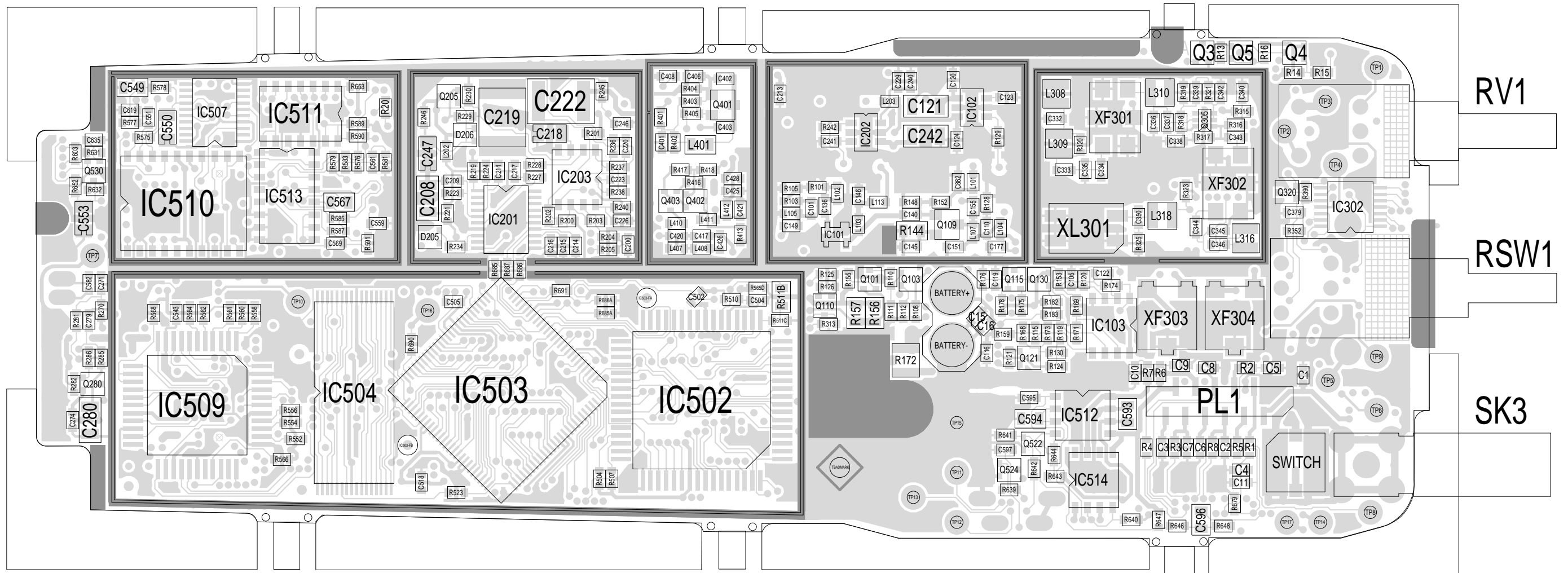

TAIT ELECTRONICS IPN: 220-01416-02 ISS: -02A ID: 1.TA DATE: 28 Apr 1999
 ORCA 800MHZ PCB LAYOUT - TOP SIDE

